



BESTMOW T100 Robotic Lawn Mower

# User Manual

Copyright © 2025 BESTMOW.com. All Rights Reserved.



# 1. Safety Warnings

## IMPORTANT READ CAREFULLY BEFORE USE KEEP FOR FUTURE REFERENCE

- **Installation and Operation:** Ensure that the BESTMOW robotic mower (referred to as “the mower” in this manual) and its charging station are installed and operated strictly according to the instructions. Visit [www.bestmow.com](http://www.bestmow.com) or access the Help & Support section via the app for the complete User Manual and the latest updates.



TEL: 1 800-882-2131  
Email: [support@bestmow.com](mailto:support@bestmow.com)

- **Intended Use:** This product is designed for **lawn mowing only**. Using it for purposes other than mowing can result in serious injury. Always read and understand all warnings and safety instructions. While following these instructions can reduce risks, it cannot eliminate them entirely. The user is responsible for ensuring safe operation and preventing accidents or hazards for others.
- **Safety Around People and Pets:** BESTMOW is equipped with **built-in safety sensors**, but risks still exist. Only schedule mowing times when no people or pets are present on the lawn. If your lawn is publicly accessible or open to neighbors, install a **fence, barrier, or warning sign** that reads:

### WARNING!

**Automatic Lawn Mower in Operation. Keep Away! Supervise Children!**

- **Unauthorized Repairs & Modifications:** DO NOT attempt to **modify, repair, or manually adjust** the mower. Unauthorized changes **can cause malfunctions, serious injury, or damage**, and may void the **warranty**. Use only **BESTMOW-approved parts and accessories**.
- **User Age & Training:** The manufacturer recommends that users be **18–70 years old**. Proper training is required before operating the mower.

### WARNING!

- NEVER allow **children, individuals with reduced physical, sensory, or mental capabilities** to operate the mower.
- Local regulations may **restrict the minimum age** for operators.

## 1.1 Before Mowing

**Pre-Check:** Regularly inspect all mower parts to ensure they function normally.

**Weather Conditions:**

- Mow only in **dry conditions** for optimal performance.
- **DO NOT** operate in extreme weather conditions.

**Lawn Inspection:**

- Before each mowing session, remove **stones, sticks, wires, toys, bones, and other foreign objects** from the lawn.
- The **warranty does not cover damage** caused by user negligence.

**Sprinkler Systems:**

- **DO NOT** schedule mowing and irrigation at the same time.

**Child Safety:**

- **NEVER allow children** to touch the **power supply, charging station, blades, battery compartment, or wheels**.

**WARNING!**

**DO NOT operate** the mower if safety guards, shields, or power cords are **damaged or missing**.

## 1.2 During Mowing

**Blade Safety:**

- **KEEP HANDS AND FEET AWAY** from rotating blades.
- **DO NOT** attempt to touch, lift, or carry the mower while the blades are moving.

**Objects in Mowing Area:**

- Beware of **thrown objects**—keep a **safe distance** while the mower is operating.

**Unattended Operation:**

- **DO NOT leave the mower unattended if pets, children, or people** are nearby.

**Safe Movement on Slopes:**

- Maintain balance and **avoid overreaching** when working on slopes.
- Walk—**never run**—while operating the mower or its peripherals.

**DO NOT mow on slopes exceeding:**

- **25° (46% slope) incline** inside the mowing area
- **15° (17% slope) incline** along boundaries

**Emergency Situations:**

- If the mower **emits an unusual sound or alarm, press the STOP button immediately**.
- If there are **abnormal vibrations**, turn off the mower, place it on level ground for **30 seconds**, and restart it. If the issue persists, contact **authorized service support**.

**WARNING!**

- **DO NOT allow children to play near the mower** while it is operating.
- **DO NOT lift or ride on the mower**.

## 1.3 Safe Usage

### Temperature Limitations:

- Operate and charge the mower **only within** the temperature range **0–40°C (32–104°F)**.
- **Extreme cold or heat can reduce performance** and lead to accidents.

### Prohibited Actions:

- **DO NOT place objects on the mower** or the charging station or canopy.
- By following these safety guidelines, you can **ensure safe and efficient** operation of your **BESTMOW robotic lawn mower**.

## 1.4 Regular Maintenance and Safe Charging Guidelines – BESTMOW

### Routine Maintenance:

- Regular maintenance should be performed by an **adult** to ensure optimal performance and longevity of the mower. (Refer to the **Maintenance** section in the User Manual for details.)
- **Check safety indicators frequently**, including:
  - The **speaker** for audible alerts
  - The **LED light** on the charging station
  - The **ambient** light on the mower

### Charging Safety Precautions:

- Before charging, **carefully read the "How to Charge" section** in the User Manual to avoid hazards. **Improper use may cause electric shock, overheating, or leakage of corrosive liquids.**
- **Only use the original battery pack** or a replacement of the same model as specified by BESTMOW. The mower contains one battery pack with a rated capacity depending on the model.
- **For battery replacements, contact after-sales service** and have a qualified technician install a new battery.

### Battery Safety Warnings:

- **DO NOT** use non-rechargeable batteries.
- For recharging, only use the **original detachable power supply unit** provided with this mower.

### Handling & Storage Precautions:

- **DO NOT dismantle or puncture the battery casing.**
- **Keep batteries away from metal objects** to prevent short circuits.
- **Store away from fire, heat sources, and direct sunlight** to avoid thermal hazards.
- For safe disposal, **contact local waste management authorities** or recycling services.

### Blade & Power Cord Safety:

- **When replacing blades**, always insert the blade installation fixture and wear protective gloves to prevent injury.
- **If the power cord or extension cable is damaged or tangled during use:**
  - **Disconnect from the power socket first** before attempting to untangle.
  - **DO NOT pull on the cord directly**; always hold the plug when disconnecting.
  - Contact after-sales service for **professional repair or replacement** of damaged cords.

By following these safety and maintenance guidelines, you can **ensure the longevity and safe operation of your BESTMOW robotic mower**.

## 1.5 Symbols and Decals



**WARNING!**

Read instruction manual before operating the machine.



**WARNING!**

Do not touch rotating blade.



**WARNING!**

Keep a safe distance from the machine when operating.



**WARNING!**

Do not ride on the machine.



**WARNING!**

Operate the disabling device before working on or lifting the machine



**WARNING!**

It is not permitted to dispose of this product as normal household waste. Ensure that the product is recycled in accordance with local legal requirements.



The recycling symbol shows that the item can be recycled



Before charging, read the instructions.



Keep the pack of this product dry



Prohibit flipping



Class II appliance



Class III appliance



Polarity of the charging port



Direct current



SMPS incorporating a short-circuit-proof safety isolating transformer (inherently or non-inherently)



Alternating current

## 2. Product Overview & Technical Specifications

### 2.1 Specifications

Capacity	
Category	Specs
Max Mowing Size	6000m <sup>2</sup> (1.5 acre)
Boundary Type	Virtual boundaries (No perimeter wire required)
Net Weight	18.8 kg
Dimension	609mm × 506mm × 264mm (23.9 in × 19.9 in × 10.4 in)
Max Climbing Ability	25° (46% slope)
Waterproof Level	IP66

Positioning & Navigation	
Feature	Details
Navigation	RTK & Vision
User Interface	APP control
Firmware Update	Over-the-Air (OTA) via App
Connectivity	2.4G Wi-Fi & Bluetooth

Cutting System	
Feature	Details
Cutting Width	220mm ( 8.7 in )
Cutting Height Range	40 - 100mm ( 1.5 - 4 in )
Mowing Speed Range	0.04 – 1m/s
Blade Type	3 pivoting stainless steel blades
Cutting Mode	Parallel stripes at a specific angle

Product Safety	
Feature	Details
Noise Level	60 dB
Object Detection & Avoidance	Camera & collision sensors
Lift Sensor	Yes
Security System	PIN access, alarm, charging station pairing, GPS theft tracking
Tilt Sensor	Yes

Battery & Charging	
Feature	Details
Battery Capacity	7.5 Ah
Battery Type	Lithium-ion
Charging Mode	Automatic & manual
Auto-Recharging	Yes
Mowing Time Per Full Charge	210 min
Charging Time	Approx. 180 minutes

## FCC Statement

This equipment complies with **FCC Part 15** regulations for Class B digital devices, designed to limit harmful interference in residential environments. While the device generates and uses radio frequency energy, proper installation minimizes potential interference with communications.

### To mitigate interference, follow these recommendations:

- Reorient or relocate the receiving antenna.
- Increase the separation between the device and receiver.
- Plug the equipment into a different electrical circuit.
- Consult a radio/TV technician for further assistance.

Unauthorized modifications may void compliance and the user's authority to operate the device.

## FCC Radiation Exposure Statement

This device meets **FCC radiation exposure limits** for uncontrolled environments. Maintain a **minimum distance of 20cm (8 inches)** between the device's radiator and your body during operation.

## IC Statement

This device complies with the **Code of Federal Regulations (CFR)** and must:

- Not cause harmful interference.
- Accept any received interference, even if it leads to undesired operation.

Users can refer to **U.S. RF exposure and compliance guidelines** for further details.

## IC Radiation Exposure Statement

Similarly, this device follows **IC radiation exposure limits** for **uncontrolled environments**, requiring a **minimum 20cm (8 inches) distance** between the equipment and the user's body.

### **WARNING!**

- This equipment meets **FCC Part 15** conditions and should not cause harmful interference while tolerating any incoming interference.
- The manufacturer **is not responsible for radio or TV interference** caused by unauthorized modifications.
- To comply with **FCC radiation exposure limits**, maintain a **minimum separation of 20 cm** from the equipment.

## 2.2 Introduction

This section provides a detailed overview of **BESTMOW**, helping you understand its advanced AI-driven capabilities and sensor technology. BESTMOW is designed to handle complex mowing scenarios autonomously.

### Multi-Map Mowing

BESTMOW supports the creation of multiple mowing maps (**up to three maps currently**). It can mow a **single lawn** or switch between **several lawns in sequence**, intelligently planning the optimal mowing path to complete the task efficiently.



### Intelligent Mowing

BESTMOW leverages **panoramic vision, RTK positioning, and visual perception technology** to enable advanced features such as: **Intelligent mapping, Precision mowing, Autonomous charging, Obstacle avoidance**



### Autonomous Charging

When the battery is low, BESTMOW **automatically pauses mowing** and returns to the charging station. Once fully charged, it **resumes the unfinished mowing task** or remains docked until the next scheduled mowing session.



### Obstacle Avoidance

Equipped with **AI-powered obstacle detection**, BESTMOW actively avoids interference from objects on the lawn. Using the **BESTMOW App**, users can mark obstacle zones to prevent the mower from entering restricted areas.



### Smart Scheduling & Security

Users can set **mowing schedules** and **security routines** via the **BESTMOW App**. The mower can either **follow a preset schedule** or activate **Watchdog Mode** for enhanced security monitoring and autonomous operation.



### Grass Clipping Mulching – No Cleanup Required

BESTMOW **cuts grass into fine clippings**, which naturally decompose and act as **organic fertilizer**, enriching the soil. **No need for collection—just a healthier, greener lawn!**





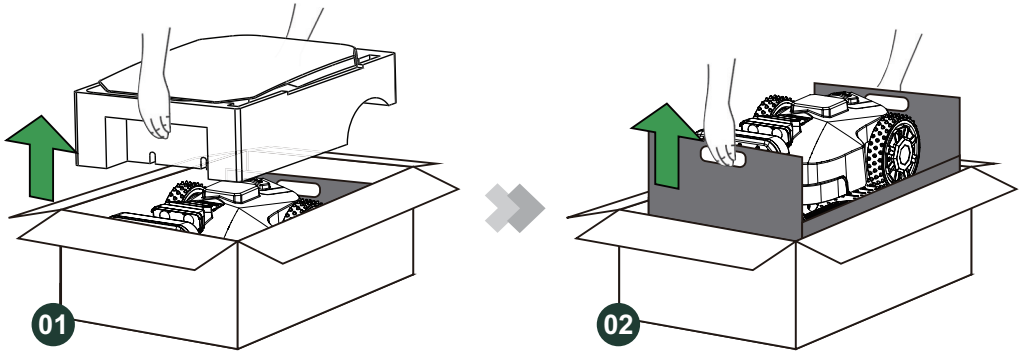

# Unboxing

Please check the items in the package shown as below

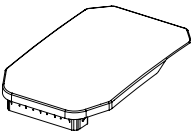
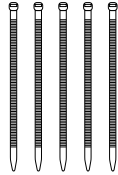
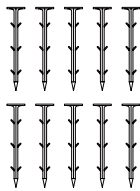

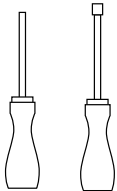
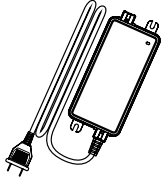
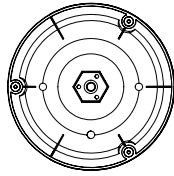
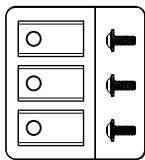
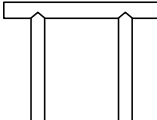
## What's inside the box

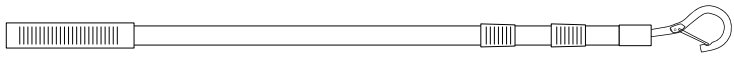
 <p>Garage (*Optional) x1</p>	 <p>Cable Ties x5</p>	 <p>Ground Peg x10</p>	 <p>Screw x8</p>	 <p>Screwdriver x2</p>
 <p>Power Adapter x1</p>	 <p>Blade Disc x1</p>	 <p>Blade Set x1 (Including 12 Blades)</p>	 <p>Blade Installation Fixture x1</p>	 <p>Stake x15</p>
 <p>User Manual x1</p>	 <p>Drag and Mow Tool x1</p>			

## 2.2.1 Main Components

Top View

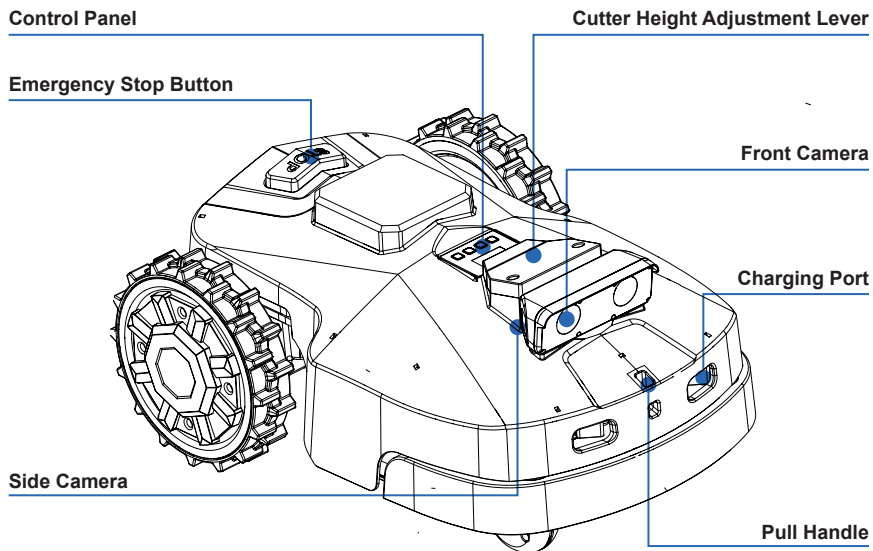

Control Panel & Display

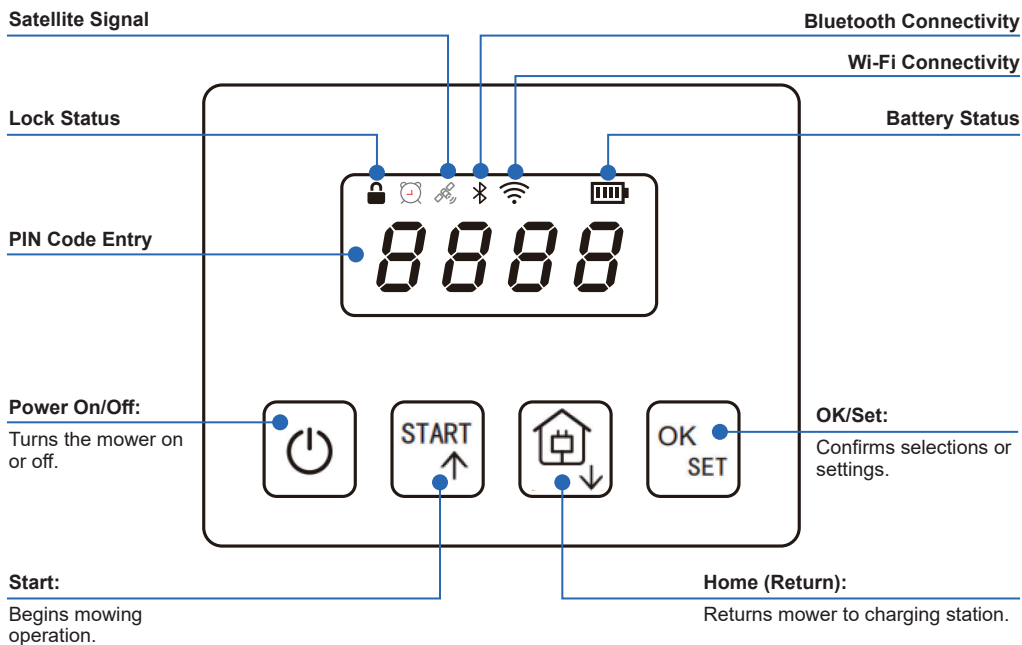

## Bottom View

The diagram below illustrates the key components of the **BESTMOW** robotic mower from the underside:

### Collision Sensor

Detects obstacles for safe navigation.

### Front Wheels

Assist in maneuverability and smooth operation on various terrains

### Blade Disc

Rotating disc that holds the cutting blades.

### Blade Fender

Protective cover over blade area.

### Battery Holder

Secures the internal battery pack.

### Blade

Precision-cutting mechanism designed for efficient and even mowing

### Handle

Allows for safe lifting and transportation.

### Rear Wheels

Provide traction and drive force.

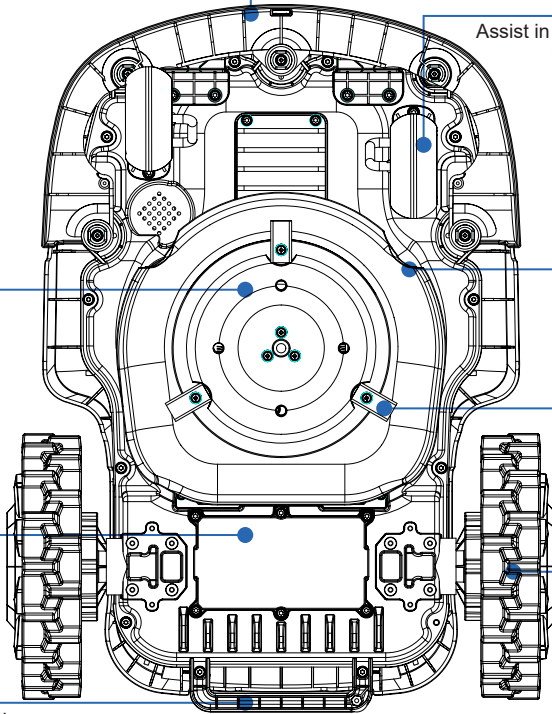

- **Power On/Off:** Press and hold the power button for **3 seconds** to turn the mower on/off.
- **Satellite:** Illuminates when satellite connection is strong.
- **Bluetooth/Wi-Fi:** Stays lit when connected; otherwise, it turns off.
- **Battery Level:** Displays battery level in three stages. Running lights indicate active charging.
- **Four-Digit Display:** Displays error codes (e.g., E-03).
- **Up and Down Buttons (Short Press):** Increase or decrease the password number by 1, or adjust the mowing height.
- **Up and Down Buttons (Long Press):** Hold ▲ to start, hold ▼ to return to the charging station.
- **OK / SET:** Confirm selection.

## 2.2.2 Unlocking Instructions

### Attention

If the mower is **locked due to an issue**, unlock it by pressing the “**Start**” and “**OK**” keys simultaneously.

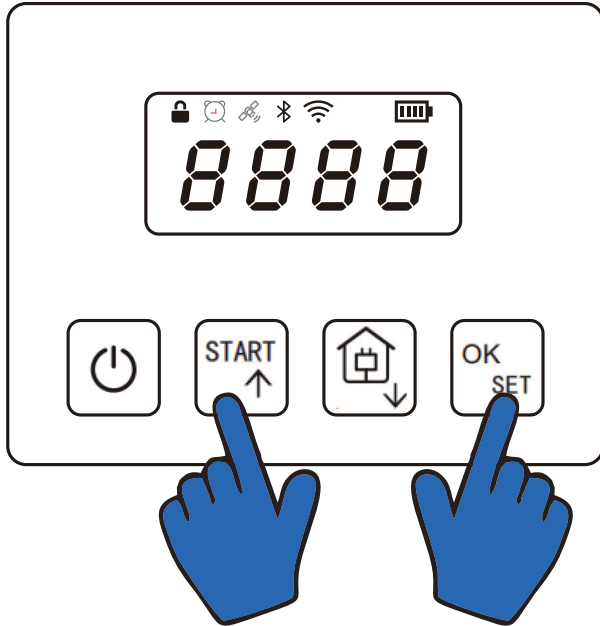

### 3. Instructions for Use

#### 3.1 Charging Pile Installation

- Select a location with **strong Wi-Fi signal** coverage.
- Ensure the charging station is placed on level ground for optimal docking.

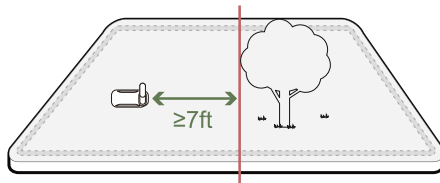
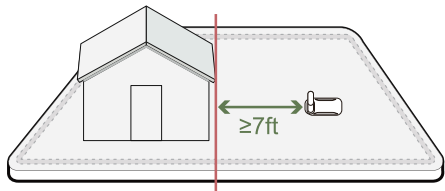

Ensure the charging station is positioned away from rooftops, tree canopies, and any large obstacles.

#### 3.2 Preparation Before Adding Devices

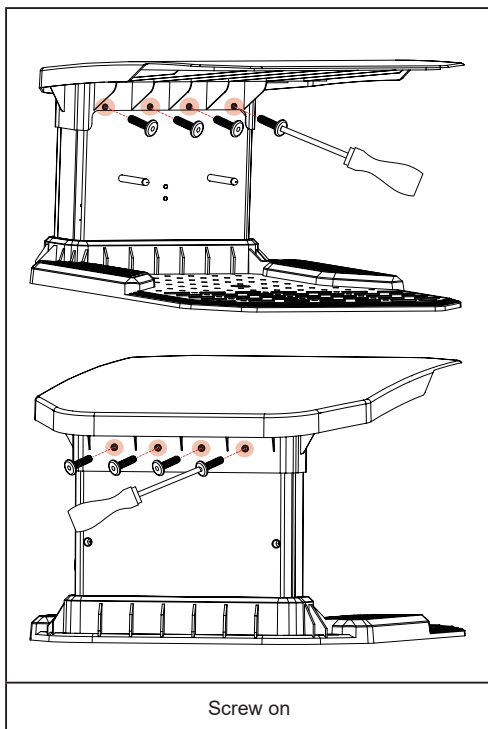
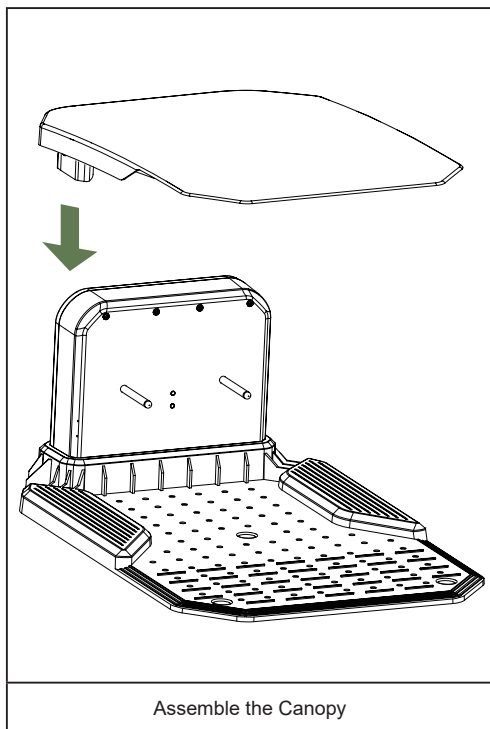

The garage is an optional accessory. Please refer to the items included in your package.  
The mower's waterproof performance is not affected by the presence or absence of the garage.

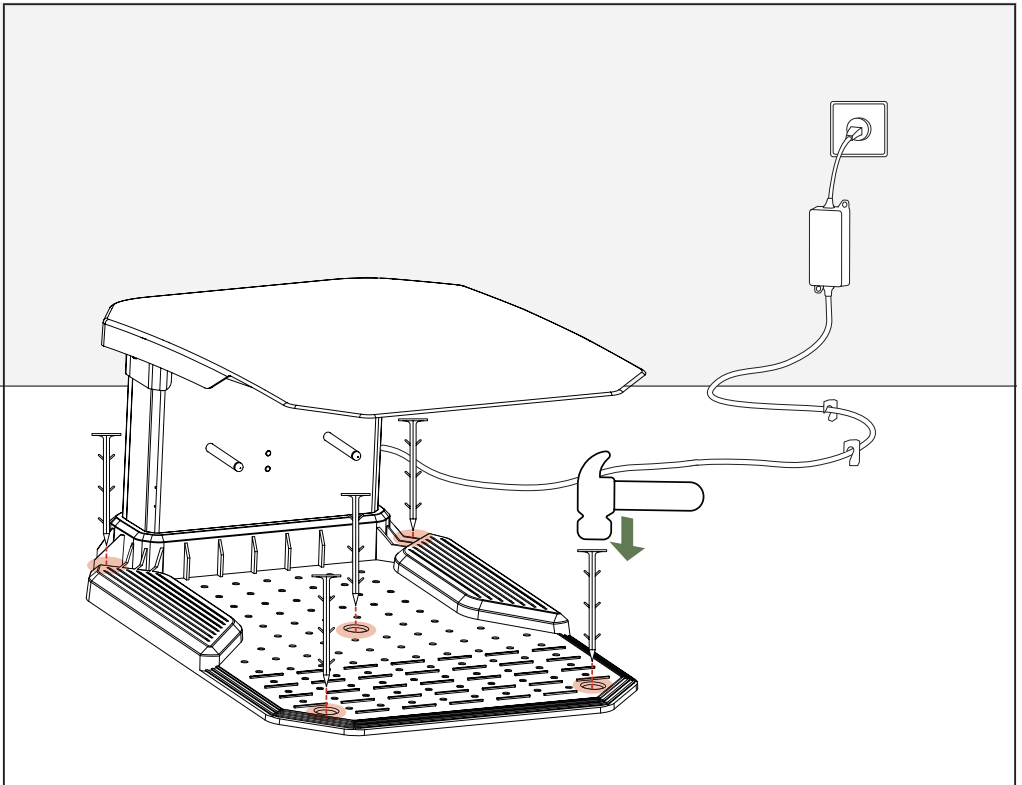

Piling and plug the power supply into a **wall socket**

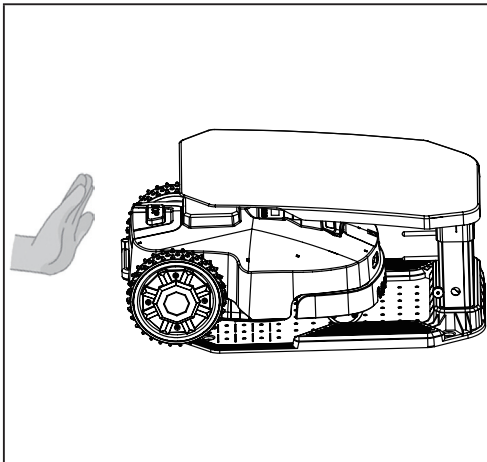

Place **BESTMOW** on charging pile

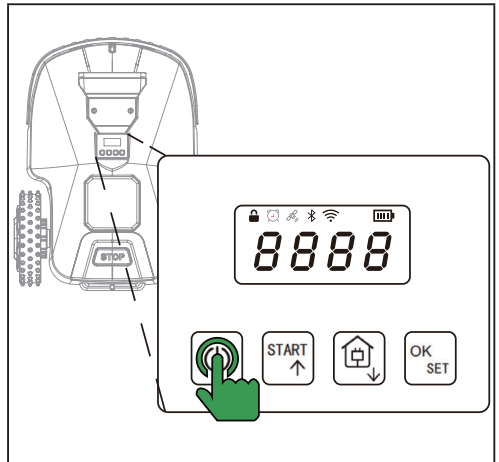

Press the **Power button** on **BESTMOW** to turn it on

### 3.3 Connect to BESTMOW

- Download the BESTMOW app from the Google Play Store or Apple App Store.
- Install the app and complete user registration.
- Log in to your account to proceed with device setup.



### 3.4 Add Device

- Click “+” to add your **BESTMOW** device.
- Follow the **on-screen instructions** to connect **BESTMOW** via **Bluetooth** and set up the network successfully.

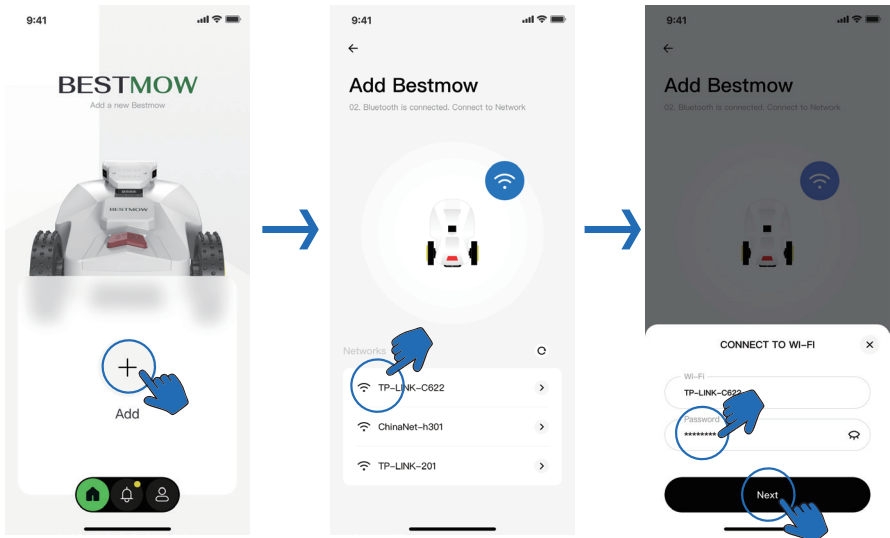

## 3.5 Mapping and Creating Inaccessible Areas

Before starting the mapping process, ensure the lawn is free of debris, leaves, toys, wires, stones, or any obstacles. Make sure no children or pets are present during mapping.

### A. Creating a Map

- Click the **Enter** button on the **Map** page in the **BESTMOW** app.
- You can either **use your phone** or **manually drag BESTMOW** to map the lawn boundary.
- Leave a **minimum clearance of 10 cm (4 in)** if mapping along walls, fences, or other obstacles.
- Avoid driving BESTMOW over uneven curbs.

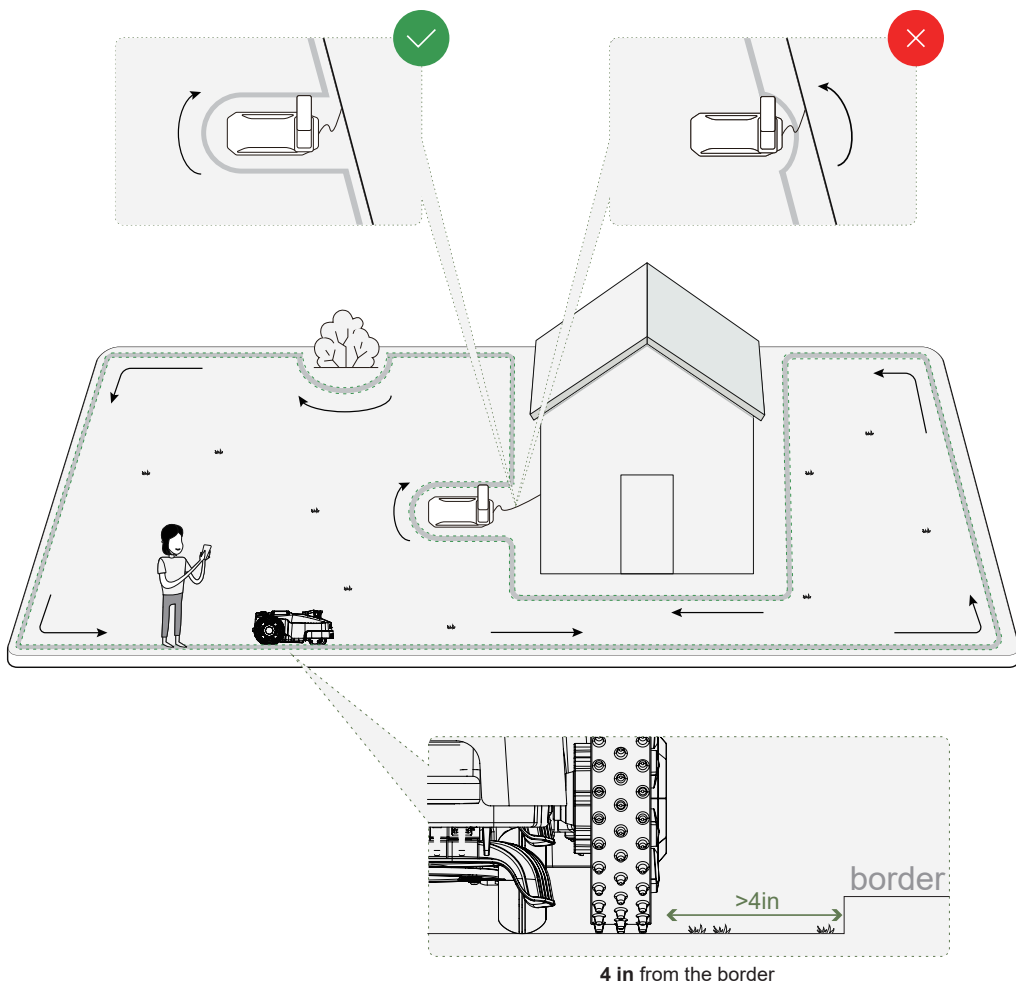
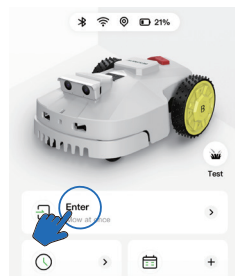

## B. Mapping Modes

### App-Driven Mapping Mode

- Drive the mower along the lawn boundary using the app controls.
- Once the mapping is accurate, **click “DONE”** to save the map
- BESTMOW will **automatically detect pathways between mowing zones** for optimized navigation.

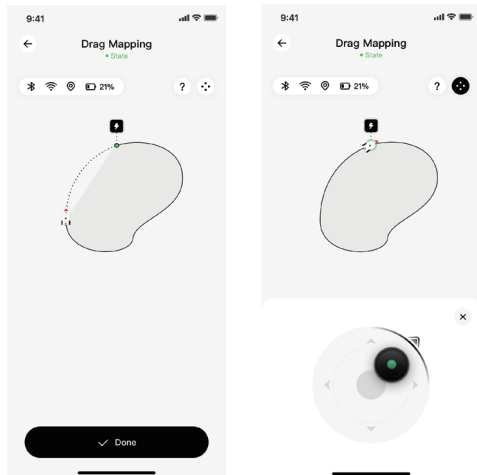

### Drag Mapping Mode

- Use the **Drag and Mow** tool in the app to drag along the edge of the lawn.
- This method allows for quick and efficient mapping using on-screen controls.

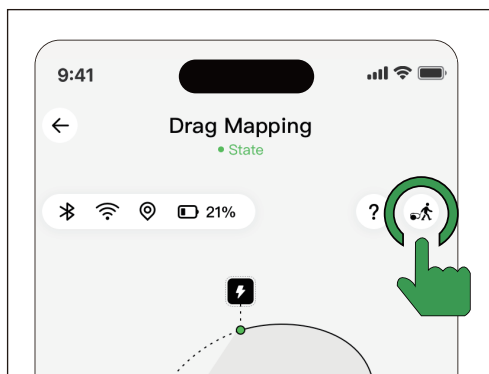

Click the **Drag Mapping** button in the APP

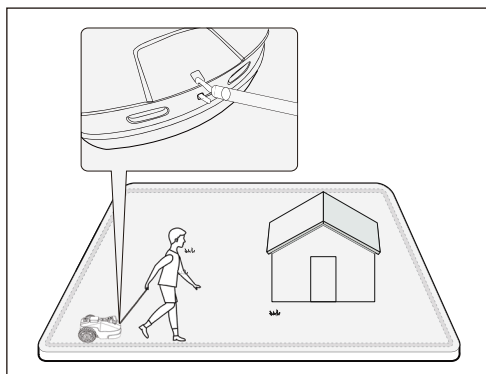

Dragging along the edge

## C. Mapping Obstacles

- Identify large fixed obstacles and **circle them** using either **App-Driven** or **Drag Mapping Mode**.
- When mapping islands (areas to be avoided), ensure the turns are **smooth and no sharper than 90°**.
- Always walk along the edge of obstacles when setting islands to ensure accurate mapping.
- Click the **Obstacle** button in the **BESTMOW** app to mark restricted zones.
- You can **manually drag** BESTMOW or use your phone to define these areas.
- These inaccessible zones prevent the mower from entering specific regions, such as pools, flower beds, or delicate landscaping.

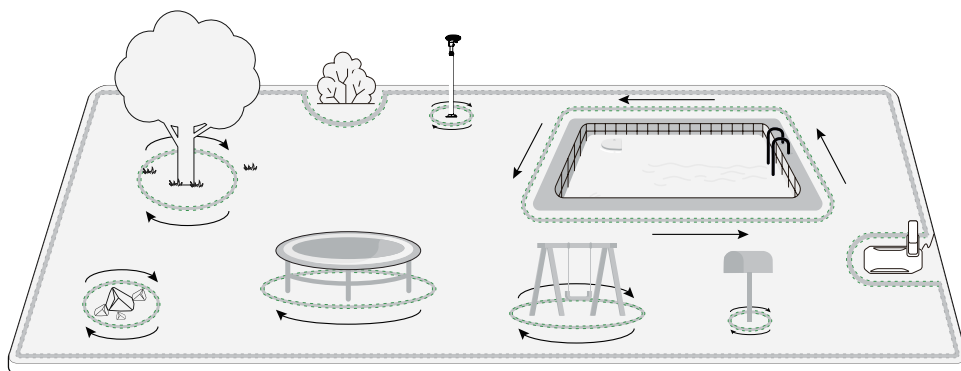
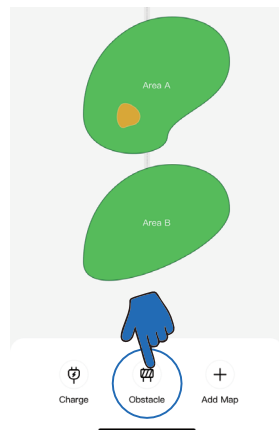

Obstacles avoidance example

## D. Finalizing the Mapping Process

- The solid line marks the **set boundary**, while the dotted line helps you navigate back to the starting point.
- The system will **automatically detect pathways** between mowing zones.

## E. Returning to the Charging Station

- Click **"Recharge"** in the app to send BESTMOW back to its charging station.
- The mower will automatically navigate to its dock and prepare for the next scheduled mowing session.

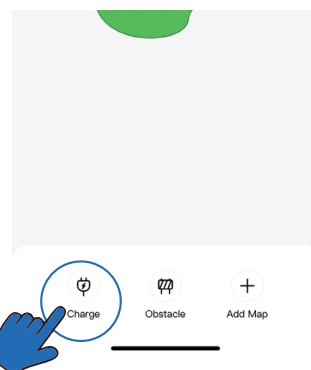

## 3.6 Mowing Settings

To start mowing, follow these steps:

- Select **"Mow" > "Automatic"** in the **BESTMOW** app to begin the mowing operation.
- Adjust the **automatic obstacle avoidance level**, which can be turned on or off based on preference.
- If obstacle avoidance is disabled, you can manually set the **avoidance level** between **1 and 4**:  
**Level 1:** Disables obstacle avoidance.  
**Level 4:** Enables full obstacle avoidance functionality.

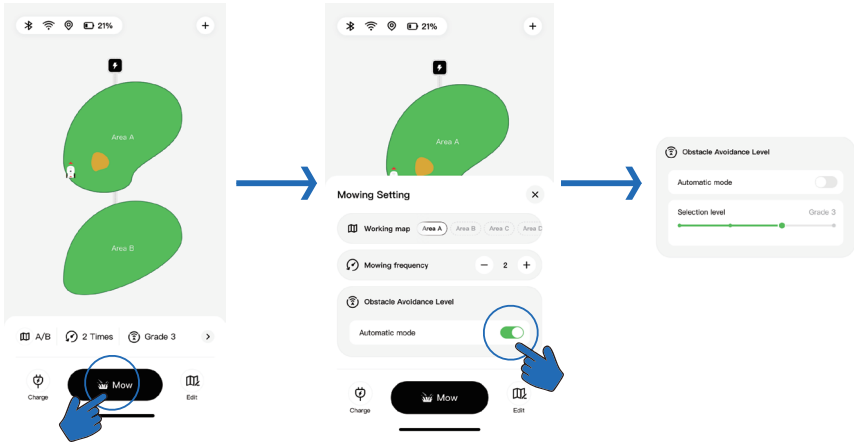

## 3.7 Mowing Height Adjustment

- The mowing height can be adjusted manually using the built-in height adjustment mechanism.
- This allows the mower to cut grass up to **4 inches**, accommodating various lawn conditions.

### Height Settings:

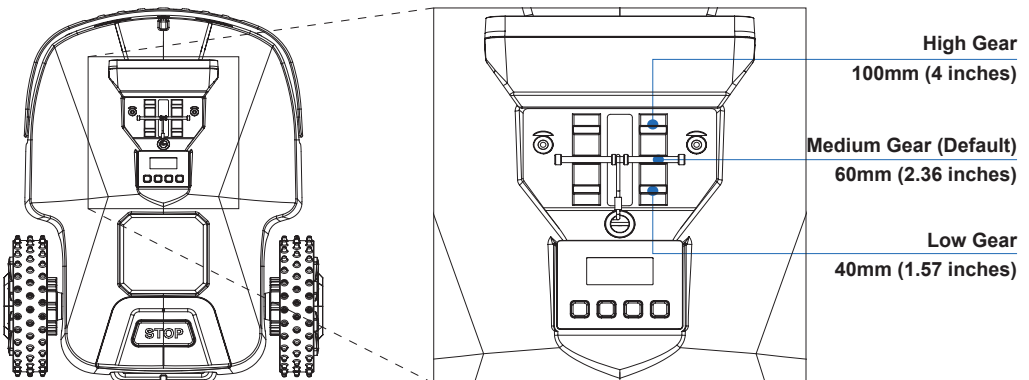

## Operating Steps:

### 1. Unscrew the lifting cover

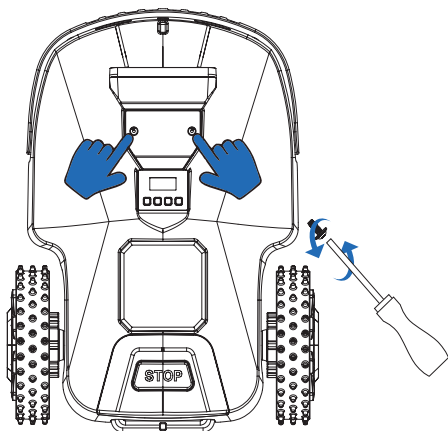

Use a screwdriver to remove the two screws securing the lifting cover.

### 2. Remove the lifting cover

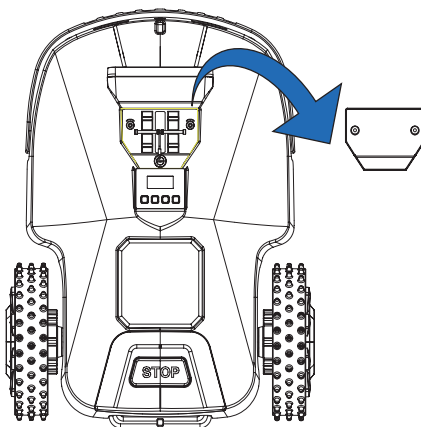

Carefully lift off the cover to access the height adjustment mechanism.

### 3. Adjust the height

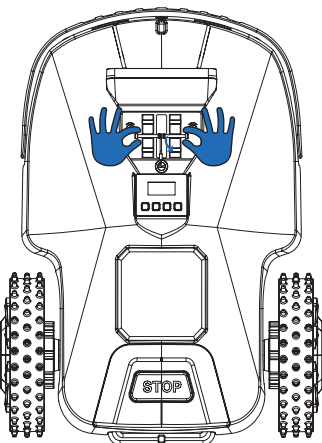

Grip the **lifting rod** with both hands and pull it out.

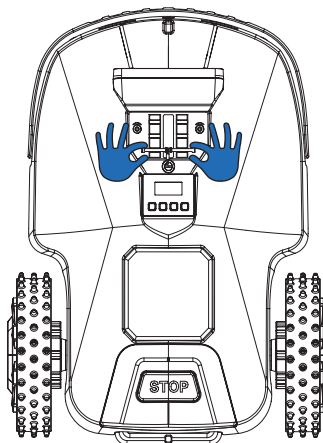

Place it into the gear corresponding to the **desired mowing height**, ensuring it fits securely into the groove.

#### 4. Reassemble the cover

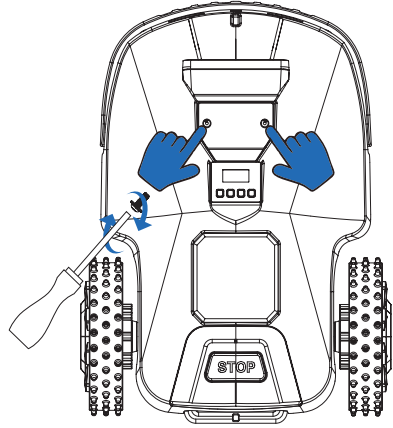
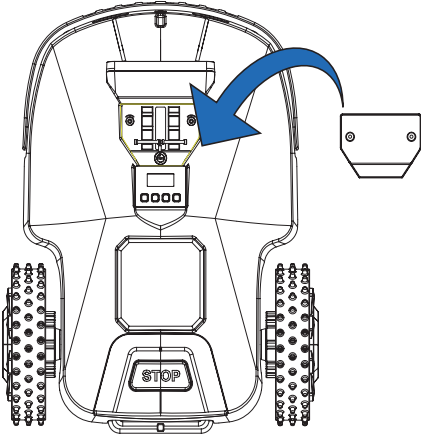

Place the lifting cover back, making sure there are **no gaps** when closed.

Tighten the two screws to secure it in place.

### 3.8 Return to Charge

#### Automatic Recharge:

- When the robotic lawn mower completes its mowing task or enters **low battery mode**, it will **automatically navigate back to the charging station**.
- To successfully recharge, the mower must be **within the designated working zones** and **not inside any no-go zone**.

#### Attention

- If the mower's **battery level drops below 20%**, it will automatically stop mowing and return to the **charging station**.
- Once the battery reaches **80% charge**, the mower will **resume from the last mowing point** and continue operation.

## Manual Recharge:

The robotic lawn mower can be manually directed to the charging station using the **top panel button** or the **BESTMOW app**.

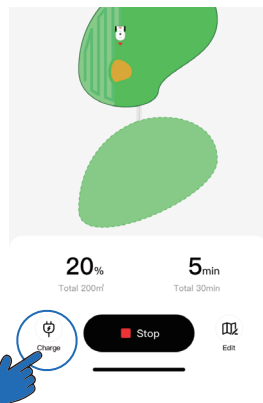

## Executing via the Top Panel Button:

- Press the **home icon**, then **OK** to confirm.
- The mower will emit a **"beep" sound**, indicating it has received the command.
- The mower will then **activate the return-to-charge function** and navigate back to the charging station.

## Executing via the App:

- Open the **BESTMOW app** and tap the **Recharge** icon on the homepage.
- Click **Confirm** to initiate the return-to-charge process.
- The mower will automatically navigate back to the charging station.

## 4. Maintenance

### 4.1 Carrying BESTMOW

#### WARNING!

- Turn off the mower before lifting or moving **BESTMOW**.
- The mower has **blades on the bottom**—handle with care to avoid injury.
- Do not lift the mower while it is **charging at the charging station**.
- For safety, **do not reach into the charging port** when carrying the machine.

#### Proper Lifting Methods:

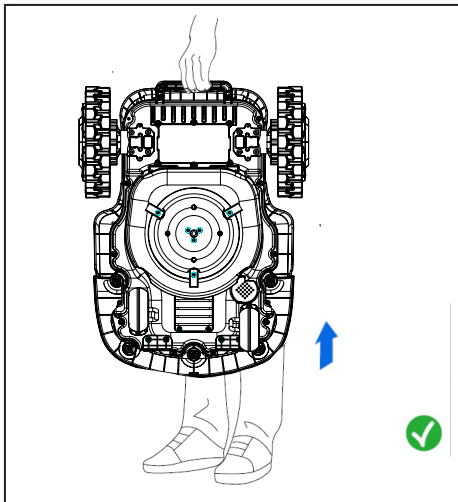

#### Blade Facing Outward:

Lift BESTMOW by the handle using one or both hands.

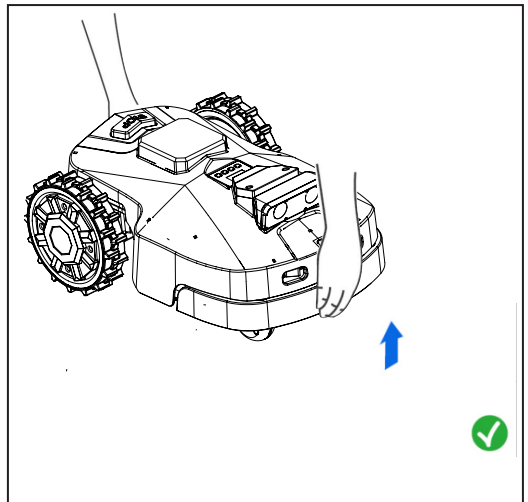

#### Blade Facing Down:

Hold the handle and front collision area with both hands.

### 4.2 Cleaning

Maintaining a proper cleaning routine will keep BESTMOW in good condition.

#### WARNING!

- **Disconnect BESTMOW from power** before cleaning.
- **Use appropriate personal protective equipment**, including gloves, protective clothing, and closed-toe shoes.
- **Avoid cleaning with corrosive agents** such as alcohol or gasoline, as they may degrade materials and components.

## General Cleaning Precautions

- Avoid using **high-pressure water jets** to prevent water from entering electronic components.
- Use **mild cleaning agents** and avoid **corrosive substances** such as alcohol or gasoline.
- When placing **BESTMOW upside down**, ensure it is on a **soft surface** to prevent scratches.

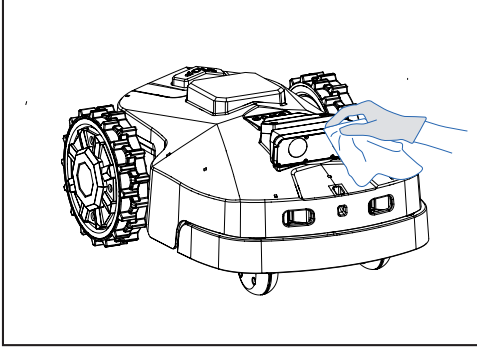

## Cleaning the Upper Body

- Wipe the upper surface and front camera using a damp cloth.
- Check for debris, such as **branches, stones, or leaves**, and remove them.
- Inspect the **charging port** for foreign objects.

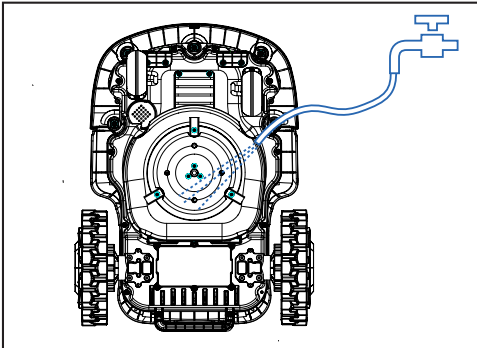

## Cleaning the Blade Disc

- Use a **brush** to remove dirt from the **blade disc**.
- Ensure the **blades are undamaged** and can **pivot freely** for smooth operation.

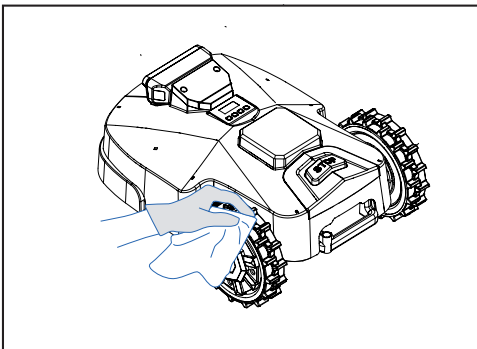

## Cleaning the Wheels

- Use a **brush** to remove dirt and debris from the wheels to maintain traction.
- After cleaning, apply a small amount of **precision machinery oil** or **WD-40** to the **moving parts** to improve lubrication.

## 4.3 Replacing the Blade Disc

### Blade Replacement Frequency

If you use the mower regularly, we recommend replacing the **blade disc** approximately **every 3 months** of operation to maintain optimal mowing efficiency.

#### Note:

- This replacement interval may need adjustment depending on the mowing area and frequency. If mowing occurs **daily**, blades may need to be replaced **monthly or less frequently**.
- Pay attention to **maintenance related tips** in the App.

#### WARNING & Residual Risks

- **BESTMOW must be powered off** before replacing the blade disc.
- **We recommend wearing gloves when changing out the blades.**
- **Use only official replacement blades**, available via the **BESTMOW app** or **BESTMOW website**. These are also provided **through the subscription plan**.
- When replacing the blade disc, **always use new screws** to ensure proper balance and stability.

### Blade Disc Replacement Steps

#### 1. Align the Cutter Disc

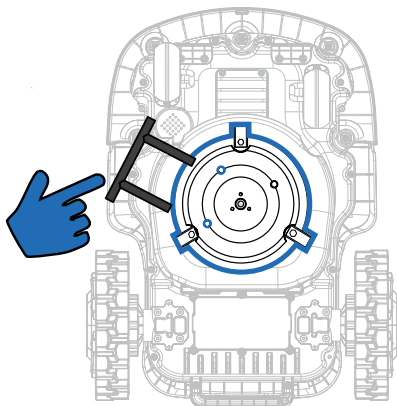

- Rotate the **cutter disc** gently until the holes align.
- Insert the **blade installation fixture** into the holes to **secure the disc** and prevent accidental cuts.

#### 2. Remove the Screws

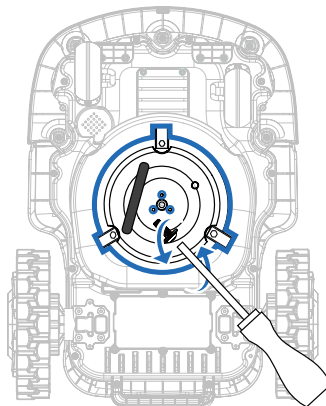

- Use a **socket screwdriver** to remove the **three screws** in the center of the blade disc.

### 3. Detach the Blade Disc

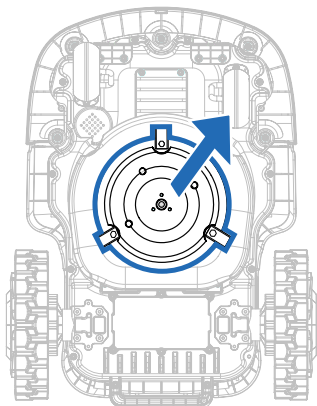

- Carefully **remove the blade disc** once the screws are detached.

### 4. Install the New Blade Disc

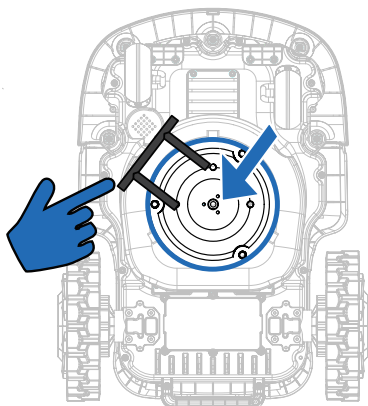

- Position the **new blade disc** onto the mower.
- Use the **blade installation fixture** to hold it in place.
- Secure it using **new screws** for stability and performance.

### 5. Tighten the Screws

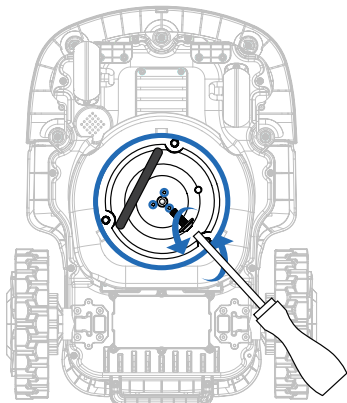

- Secure the **three screws** tightly to ensure stability.

### 6. Lock the Blades

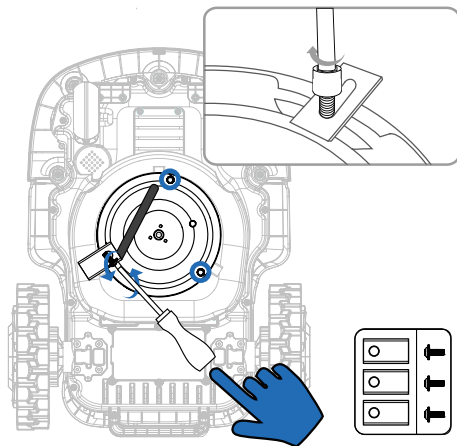

- Prepare the **blade set** and use a **socket-head screwdriver** to attach the blades onto the blade disc.

### 7. Secure the Blades

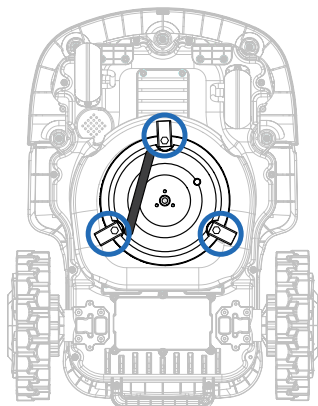

- Ensure that all **three blades** are firmly locked in place.

### 8. Remove the Blade Installation Fixture

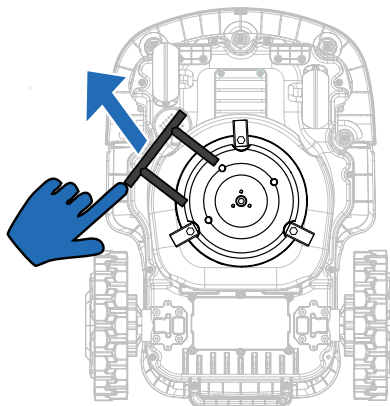

- After securing the blades, **remove the blade installation fixture** to allow the cutter disc to rotate properly.

### Important Notes:

- After installing new blades, **remove the blade installation fixture** before operation.
  - If left in place, the cutter disc **will not rotate**, which may **damage the motor**.
- If you are **only replacing the blades** (not the entire disc):
  1. Secure the **blade installation fixture**.
  2. Remove the **old blades**.
  3. Follow steps **6–8** to install the **new blades**.

## 4.4 Changing the Battery

When the **BESTMOW** app notifies you that **battery health is too low**, or if the battery performance significantly declines, the **official BESTMOW battery** needs to be replaced. The battery is available via the **BESTMOW app store** or **BESTMOW website**.

### Subscription Plan:

- The **BESTMOW subscription** provides a **free battery replacement**, so users do not need to purchase a new battery separately.

#### Attention

- The **battery cannot be charged alone** -it must be charged using the BESTMOW charging station.
- **Only use an authorized BESTMOW battery.**
- **Do not replace the battery without the permission of the staff.**
- Install the new battery **according to the polarity markings** on the battery case.
- **Before disposal, wrap exposed metal terminals** with insulating tape to prevent short circuits.

### Attention

- If **battery liquid contacts skin or clothing**, rinse immediately with water. If it enters the **eyes**, **do not rub**, rinse thoroughly, and seek medical attention.
- **Battery Disposal**: Contact your local **waste management office** for proper disposal.

## 4.5 Steering wheel maintenance

When the **BESTMOW** App notifies you that the steering wheel needs maintenance, or if you experience difficulty turning, you need to lubricate the steering wheel.

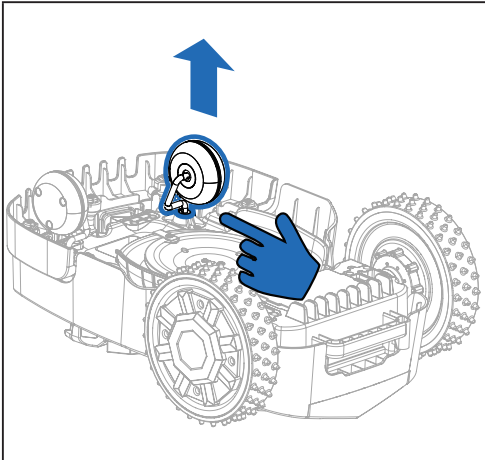

1. Lift the front wheel.

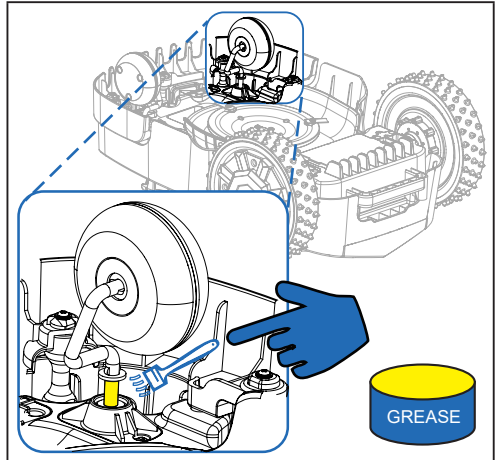

2. Apply lubricant grease to the lifted part of the front axle.

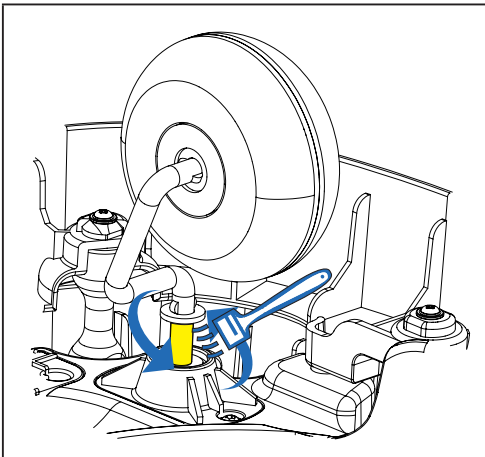

3. Rotate the wheel to evenly distribute grease along the moving components.

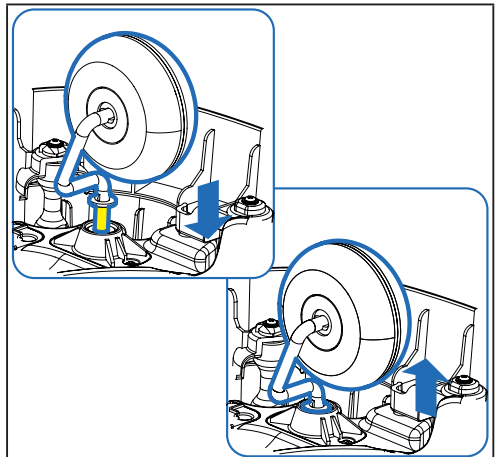

4. Move the wheel up and down until grease fully coats the axle mechanism.

## 4.6 Storage

### Storing BESTMOW:

- **Avoid extreme temperatures.** Store in an environment between 0°C to 45°C (32°F to 113°F).
- Store in a **dry, low-humidity location** free of **dust and corrosive gases**.

### Storing the Battery:

- **Ensure the battery is fully charged before storage.**
- **Recommended storage temperature: 0°C to 45°C (32°F to 113°F).**
- Store in a **low-humidity, dust-free, and corrosion-free environment.**
- **Recharge every 60 days** to prevent battery damage.

#### Attention

Failure to follow this guideline may void the warranty.

## 5. Troubleshooting

### Attention

Before troubleshooting, ensure the following:

- **APP software** is updated to the latest version.
- **BESTMOW software** is updated to the latest version.
- **Mobile device system** is running the latest version.

If the issue persists, contact **BESTMOW after-sales service** via the app or official website. If the product is still under warranty, report the failure for support.

### Charging & Battery Issues

SYMPTOM	CAUSE	SOLUTIONS
<b>BESTMOW cannot charge</b>	<ul style="list-style-type: none"><li>• Power supply failure.</li><li>• Charging plug not connected or dirty.</li><li>• Battery temperature too high/low.</li></ul>	<ul style="list-style-type: none"><li>• Check the power supply.</li><li>• Ensure the contacts are connected properly and clean.</li><li>• Wait for the temperature to return to normal before charging.</li></ul>
<b>Charging time exceeds the rated time</b>	<ul style="list-style-type: none"><li>• Foreign objects or dirt on the charging contacts.</li></ul>	<ul style="list-style-type: none"><li>• Clean the contacts.</li></ul>
<b>Shorter charging time</b>	<ul style="list-style-type: none"><li>• Battery health is lower than normal.</li><li>• Poor contact at the charging point.</li></ul>	<ul style="list-style-type: none"><li>• Replace with a <b>BESTMOW original battery</b>.</li><li>• Check the charging point and plug.</li></ul>
<b>LED light on the charging station does not turn on</b>	<ul style="list-style-type: none"><li>• Power adapter is faulty or malfunctioning.</li></ul>	<ul style="list-style-type: none"><li>• Check the power supply.</li></ul>
<b>BESTMOW cannot connect to the charging station</b>	<ul style="list-style-type: none"><li>• Identification code on the charging plug is blocked/stained, affecting visual positioning.</li><li>• Foreign objects or dirt on the charging plug.</li></ul>	<ul style="list-style-type: none"><li>• Remove/clean the covering.</li><li>• Clean the charging plug.</li></ul>
<b>BESTMOW shuts off when docking the charging station</b>	<ul style="list-style-type: none"><li>• Power supply/mower temperature is too high.</li><li>• Charging plug is dirty.</li></ul>	<ul style="list-style-type: none"><li>• If ambient temperature is too high, remove the adapter and wait for cooling before charging.</li><li>• Clean the charging plug.</li></ul>

## Mowing & Security Troubleshooting

Please reach out to BESTMOW support team or utilize the chart below

**TEL: 1 800-882-2131**

**Email: support@bestmow.com**

### WARNING!

- If BESTMOW encounters an issue during mowing or security operation, press the red stop button to stop the machine.
- After resolving the issue, BESTMOW will automatically resume its task and return to the charging station if necessary.

SYMPTOM	CAUSE	SOLUTIONS
<b>BESTMOW is stuck.</b>	<ul style="list-style-type: none"> <li>• Trapped in multiple obstacle areas.</li> <li>• On a steep slope, soft sand, or deep ditch.</li> <li>• Reduced wheel traction.</li> <li>• Cutting height set too low.</li> </ul>	<ul style="list-style-type: none"> <li>• Set the trapped location as an <b>obstacle area</b> in the app.</li> <li>• <b>Flatten the lawn</b> or set it as an obstacle area.</li> <li>• <b>Remove debris</b> (stones, soil, etc.) from wheels.</li> <li>• <b>Increase cutting height</b> gradually.</li> </ul>
<b>BESTMOW slipping.</b>	<ul style="list-style-type: none"> <li>• Wet grass.</li> <li>• On a steep slope.</li> <li>• Reduced wheel traction.</li> <li>• Stuck by branches or stones.</li> </ul>	<ul style="list-style-type: none"> <li>• <b>Wait for the lawn to dry</b> before mowing.</li> <li>• Flatten the lawn or set as an obstacle area.</li> <li>• Remove <b>stones, soil, or debris</b> from wheels.</li> <li>• <b>Clean the mower's bottom.</b></li> </ul>
<b>Vibration / abnormal sound.</b>	<ul style="list-style-type: none"> <li>• Unbalanced or damaged blade disc.</li> <li>• Use of unofficial blades.</li> <li>• Incorrect blade count (too few or too many).</li> </ul>	<ul style="list-style-type: none"> <li>• <b>Inspect the blade disc and blades;</b> replace if necessary.</li> <li>• <b>Use only official blades</b> (available via the <b>BESTMOW app/website</b>).</li> <li>• <b>Check the number of blades</b> for balance.</li> </ul>
<b>BESTMOW does not work within the set area.</b>	<ul style="list-style-type: none"> <li>• Time zone settings are out of sync.</li> <li>• Incorrect scheduling settings.</li> </ul>	<ul style="list-style-type: none"> <li>• <b>Sync the app time with BESTMOW.</b></li> <li>• <b>Confirm and adjust the mowing schedule</b> in the app.</li> </ul>
<b>BESTMOW does not respond when pressing the start button.</b>	<ul style="list-style-type: none"> <li>• Stop button is stuck.</li> </ul>	<ul style="list-style-type: none"> <li>• <b>Check if the stop button is jammed.</b></li> </ul>

## Uneven Mowing Height & Adjustment Issues

SYMPTOM	CAUSE	SOLUTIONS
<b>Uneven mowing height.</b>	<ul style="list-style-type: none"> <li>Single mowing time is too short.</li> <li>Mowing area is too large or grass is too high.</li> <li>Unbalanced/damaged blade disc.</li> <li>Cutting height is set too low.</li> </ul>	<ul style="list-style-type: none"> <li><b>Increase mowing time.</b></li> <li><b>Reduce mowing area or increase cutting height gradually.</b></li> <li><b>Inspect the blade disc and blades;</b> replace if necessary.</li> <li><b>Adjust cutting height</b> as needed.</li> </ul>

## Signal & Connectivity Troubleshooting

SYMPTOM	CAUSE	SOLUTIONS
<b>Bluetooth connection failed.</b>	<ul style="list-style-type: none"> <li>BESTMOW system error.</li> <li>Possible hardware damage.</li> </ul>	<ul style="list-style-type: none"> <li>Restart BESTMOW App. If the issue persists, contact after-sales service.</li> </ul>
<b>Bluetooth signal is unstable / interrupted.</b>	<ul style="list-style-type: none"> <li>BESTMOW system error.</li> <li>Device is too far from the mobile phone Bluetooth connection.</li> </ul>	<ul style="list-style-type: none"> <li>Restart BESTMOW App. If the issue persists, contact after-sales service.</li> <li>Keep the <b>mobile phone and BESTMOW within 1-2 meters.</b></li> </ul>
<b>Wi-Fi connection failed.</b>	<ul style="list-style-type: none"> <li>BESTMOW system error.</li> <li>Device is too far from the home Wi-Fi.</li> <li>Wi-Fi is unrecognized.</li> </ul>	<ul style="list-style-type: none"> <li>Restart BESTMOW App. If the issue persists, contact after-sales service.</li> <li>Relocate the charging station nearer to your home Wi-Fi network.</li> <li>Restart the home Wi-Fi or update the Wi-Fi password.</li> </ul>
<b>Unstable / interrupted Wi-Fi signal.</b>	<ul style="list-style-type: none"> <li>BESTMOW system error.</li> <li>Too far from home Wi-Fi.</li> </ul>	<ul style="list-style-type: none"> <li>Restart BESTMOW App. If the issue persists, contact after-sales service.</li> <li>Relocate the charging station nearer to your home Wi-Fi network.</li> </ul>
<b>Weak GPS signal.</b>	<ul style="list-style-type: none"> <li>BESTMOW system error.</li> <li>Obstacles blocking the GNSS antenna signal.</li> </ul>	<ul style="list-style-type: none"> <li>Restart BESTMOW App. If the issue persists, contact after-sales service.</li> <li>Place the robot in an open and unobstructed location.</li> </ul>

## Installation & Mapping Troubleshooting

SYMPTOM	CAUSE	SOLUTIONS
<b>BESTMOW operation is delayed / uncontrolled during mapping.</b>	<ul style="list-style-type: none"> <li>• BESTMOW system error.</li> <li>• Mobile phone Bluetooth is too far from BESTMOW.</li> </ul>	<ul style="list-style-type: none"> <li>• Restart BESTMOW App. If the issue persists, contact after-sales service.</li> <li>• <b>Keep the mobile phone and BESTMOW within 1–2 meters.</b></li> </ul>
<b>Bluetooth connection failed.</b>	<ul style="list-style-type: none"> <li>• BESTMOW system error.</li> <li>• Mobile phone Bluetooth or system version is outdated.</li> </ul>	<ul style="list-style-type: none"> <li>• Restart BESTMOW App. If the issue persists, contact after-sales service.</li> <li>• <b>Update the mobile phone Bluetooth and system to the latest version.</b></li> </ul>
<b>Bluetooth signal is unstable / interrupted.</b>	<ul style="list-style-type: none"> <li>• BESTMOW system error.</li> <li>• Device is too far from the mobile phone Bluetooth connection.</li> </ul>	<ul style="list-style-type: none"> <li>• Restart BESTMOW App. If the issue persists, contact after-sales service.</li> <li>• <b>Keep the mobile phone and BESTMOW within 1–2 meters.</b></li> </ul>
<b>Wi-Fi connection failed.</b>	<ul style="list-style-type: none"> <li>• BESTMOW only supports 2.4G Wi-Fi, compatibility issues may arise.</li> </ul>	<ul style="list-style-type: none"> <li>• Contact after-sales service for assistance.</li> </ul>
<b>Unstable / interrupted Wi-Fi signal.</b>	<ul style="list-style-type: none"> <li>• BESTMOW system error.</li> <li>• Too far from home Wi-Fi.</li> </ul>	<ul style="list-style-type: none"> <li>• Restart BESTMOW. If the issue persists, contact after-sales service.</li> <li>• <b>Relocate the charging station nearer to your home Wi-Fi network.</b></li> </ul>



*"A Robot On Every Lawn"*

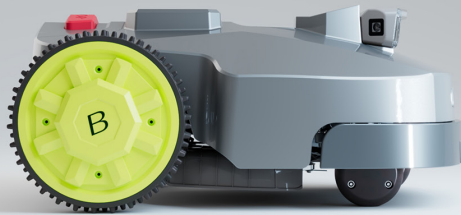

**TEL: 1 800-882-2131**  
**Email: [support@bestmow.com](mailto:support@bestmow.com)**



[@tiktok.com/@bestmow](https://www.tiktok.com/@bestmow)  
[@bestmow\\_north\\_america](https://www.tiktok.com/@bestmow_north_america)  
[@bestmow\\_official](https://www.tiktok.com/@bestmow_official)



[youtube.com/  
@bestmow](https://www.youtube.com/@bestmow)



[facebook.com/  
BESTMOWROBOT](https://www.facebook.com/BESTMOWROBOT)



[instagram.com/  
bestmow](https://www.instagram.com/bestmow)